



# Nano TX V2 Module User Manual



Welcome to ExpressLRS!



# ExpressLRS | BETAFPV

ExpressLRS is a new generation of open-source wireless remote control system dedicated to providing the best wireless link for FPV Racing. It is based on the fantastic Semtech SX127x/SX1280 LoRa hardware combined with an Espressif or STM32 Processor, with characteristics such as long remote control distance, stable connection, low latency, high refresh rate, and flexible configuration.

BETAFPV Nano TX V2 module is a high-performance wireless remote control product based on ExpressLRS V3.3, with strong anti-interference performance and stable signal link. It adds the custom button and Backpack function based on the previous Nano RF module, improves its RF transmission power to 1W/2W and redesigns the heat dissipation structure. All the updates make the Nano TX V2 module enjoy simpler operation, better performance and be more suitable for applications such as racing, long-range flights, and aerial photography, which require high signal stability and low latency.

Github Project Link: <https://github.com/ExpressLRS>

Specifications:

2.4GHz Version

● Packet Rate:

50Hz/100Hz/150Hz/250Hz/333Hz/500Hz/D250/D500/F500/F1000

● RF output Power:

25mW/50mW/100mW/250mW/500mW/1000mW

● Frequency Band: 2.4GHz ISM

● Power Consumption: 8V,1A@1000mW, 150Hz, 1:128

● Antenna Port: RP-SMA

## 915MHz&868MHz Version

- Packet Rate: 25Hz/50Hz/100Hz/100Hz Full/200Hz/D50
- RF output Power:  
10mW/25mW/50mW/100mW/250mW/500mW/1000mW/2000mW
- Frequency Band: 915MHz FCC/868MHz EU
- Power Consumption: 8V,1A@1000mW,50Hz, 1:128
- Antenna Port: SMA
  
- Input Voltage: 7V~13V
- USB Port: Type-C
- USB Power Supply Range: 7-13V(2-3S)
- Built-in Fan Voltage: 5V

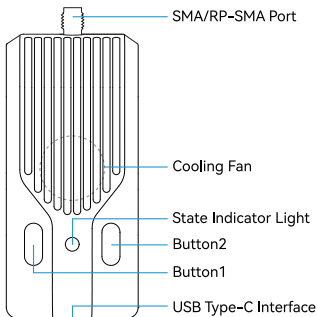

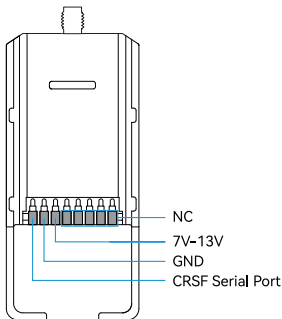

**Note:** Please assemble the antenna before powering on. Otherwise, the PA chip will be damaged permanently.

BETA FPV Nano TX V2 Module is compatible with all the radio transmitter which has the nano module bay (AKA Lite module bay, e.g. BETA FPV LiteRadio 3 Pro、Radiomaster Zorro/Pocket、Jumper T Pro V2/T20、TBS Tango 2 ).

## Indicator Status

Receiver Indicator Status Includes:

| Indicator Color | Status      | Indicating              |
|-----------------|-------------|-------------------------|
| Rainbow         | Fade Effect | Power On                |
| Green           | Slow Flash  | WiFi Update Mode        |
| Blue            | Slow Flash  | Bluetooth Joystick Mode |
| Red             | Fast Flash  | RF chip not detected    |
| Orange          | Slow Flash  | No handset connection   |

| Indicator Color | Status     | Indicating                                    |
|-----------------|------------|---|
|                 | Solid On   | Connected and color indicates packet rate     |
|                 | Slow Flash | No connection and color indicates packet rate |

The packet rate correspond to the RGB indicator color as shown below:

2.4GHz:

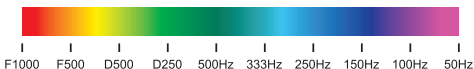

915MHz/868MHz:

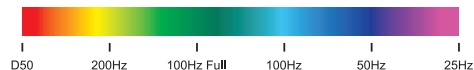

F1000 and F500 are the only packet rates in FLRC mode, only supported by ELRS 2.4G. This mode features a lower latency rate and faster configuration. However, the distance of remote control would be shorter than standard LoRa mode. It's better suitable for racing purposes.

D500 and D520 are packet rates under DVDA (Déjà Vu Diversity Aid) mode. Works under F1000 rate of FLRC mode. It repeatedly sends multiple identical packets under a complex environment, ensuring a safer radio link connection. D500 and D250 represent sending the same data packet twice and four times, respectively.

D50 is an exclusive mode under ELRS Team900. It will send the same packets four times repeatedly under 200Hz Lora Mode, with a remote control distance equivalent to 200Hz.

100Hz Full is the mode that achieves 16-channel full resolution output at the 200Hz packet rates of Lora mode, with a remote control distance equivalent to 200Hz.

## Transmitter Configuration

The Nano TX V2 module defaults to receive signals in the Crossfire serial data protocol (CRSF), so the TX module interface of the remote control needs to support CRSF signal output. Taking the EdgeTX remote control system as an example, the following explains how to configure the remote control to output CRSF signals and control the TX module using Lua scripts.

### CRSF Protocol

In the EdgeTX system, select "MODEL SEL" and enter the "SETUP" interface. In this interface, turn off Internal RF (set to "OFF"), turn on External RF, and set the output mode to CRSF. Connect the module correctly and then the module will function properly.

Settings are shown below:

|              |             |
|--------------|-------------|
| <b>SETUP</b> | 2/12        |
| Internal RF  |             |
| Mode         | OFF         |
| External RF  |             |
| Mode         | <b>CRSF</b> |
| Baudrate     | 921k        |
| Status       | 500Hz 0Err  |
| Ch. Range    | CH1-16      |

### Lua Script

Lua is a lightweight and compact script language. It can be used by being embedded in radio transmitters and easily reading and modifying the parameter set of modules. The directions for using Lua are as below.

- Download the elrsV3.lua on BETAFPV official website or ExpressLRS configurator.

⚙️
Target

Device category  
 BETAFPV 2.4 GHz

Device  
 BETAFPV Nano 2.4GHz TX V2

**Flashing Method**  
 UART ?   
  WIFI ?

DOWNLOAD LUA SCRIPT

⚙️
Device options
RESET

Standard mode   
  Manual mode

- Save the elrsV3.lua files onto the radio transmitter's SD Card in the Scripts/Tools folder;
- Press the "SYS" button or the "Menu" button on the EdgeTX system to access the "Tools" interface where you can choose "ExpressLRS" and run it.
- The below images show the Lua script if it runs successfully.

```

BFPV Nano TX V2    0/1000 C
Packet Rate    F1000(-104dbm)
Telem Ratio    Std(1:64)
Switch Mode    Wide
Model Match    Off(ID: 0)
> TX Power(100mw)
> VTX Administrator
> WiFi Connectivity
> Backpack
  [BLE Joystick]
  [Bind]
3.3.1 ISM2G4 b08b82
> Other Device
  
```

- With the Lua script, users could configure the set of parameters, such as Packet Rate, Telem Ratio, TX Power , and the like. The main functions of Lua script are shown in the table below. All function introductions can be viewed on the technical support page of the official website.

| Parameter              | Note  |
|------------------------|---|
| BFPV Nano TX V2        | Products Name, up to 15 characters.   |
| 0/250                  | Drop ratio of the communication between radio control and module.<br>i.e. the TX module received 250 packets and lost 0 packets.  |
| C/-                    | C: Connected<br>-: Unconnected  |
| Packet Rate            | Packet rate of communication between module and receiver, and the shorter the interval between remote control packets sent by the transmitter, the more precise the control is. |
| Telem Ratio            | Receiver telemetry ratio.<br>e.g., 1:64 means that the receiver will send one telemetry packet back for every 64 remote control packets it receives.                            |
| TX Power               | Configure the RF transmission power of module, dynamic power, and the threshold for cooling fan.  |
| WiFi Connectivity      | Enable the WiFi of module/receiver/backpack of VRX.   |
| Bind                   | Enter the binding mode.   |
| 3.3.0 ISM2G4<br>b08b82 | Firmware version, frequency band and serial number.<br>The factory firmware version and serial number may vary.   |

**Note:** Learn more details of ExpressLRS Lua here: <https://www.expresslrs.org/quick-start/transmitters/lua-howto/>.



## Custom Button

There are two buttons reserved for users to customize its functions. Operation steps are shown below:

- Enter the WiFi mode through enable module or powering on for 60 seconds;
- Once the RGB state indicator is in slow green flashing, the receiver's WiFi will be activated (WiFi name: ExpressLRS TX, password: expresslrs);
- Connect your phone or computer to WiFi, and log in to the browser at <http://10.0.0.1>. You will be able to find the custom button settings page.
- In the "Action" column, select desired custom Function; In the "Press" and "Count" columns, select the button press type and the number of presses or duration of the press.
- Click "Save" to complete the configuration.

There are six settable shortcut buttons and two ways to use the buttons: long press and short press. Long press can be set to a custom time duration, while short press can be set to a custom number of presses.

Six settable functions are shown below:

|                            |                      |
|----------------------------|----------------------|
| • Unused                   | • Send VTX Settings  |
| • Increase Power Output    | • Enable WiFi        |
| • Go to VTX Channel Menu   | • Enter Binding Mode |
| • Go to VTX Frequency Menu |                      |

Default functions of the module are shown as below:

| Button                   | Action             | Press       | Count           |
|--------------------------|--------------------|-------------|-----------------|
| Button1<br>(Left Button) | Enter Binding Mode | Short Press | 3 Times         |
|                          | Increase Power     | Long Press  | For 0.5 seconds |

| Button                    | Action                 | Press       | Count           |
|---------------------------|------------------------|-------------|-----------------|
| Button2<br>(Right Button) | Go to VTX Channel Menu | Short Press | 2 Times         |
|                           | Send VTX Settings      | Long Press  | For 0.5 seconds |

## Bind

The default firmware of Nano TX V2 module is ExpressLRS version 3.3.0. There is no Binding Phrase pre-set. Hence Binding with transmitters has to ensure that the receiver is using V3.0.0 above with no binding phrase.

1. Put the receiver into binding mode and wait for connection.
2. Quick press the button 1 (Left button) for three times to enter the binding mode(factory default setting), or you can enter binding mode by clicking 'Bind' in the Lua script. if the Indicator has turned solid, it indicates that the device has been bound successfully.

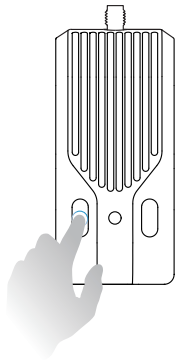

Quick Press the Button 1 (Left Button)  
for Three Times to Enter the Binding Mode

Note: If the transmitter module has been reflashed with a binding phrase, then using the above binding method will not be bound to other devices. Please set the same binding phrase for the receiver to perform automatic binding.

## External Power

The power consumption of the Nano TX V2 module when using a transmission power of 500mW or above is relatively high, which will shorten the usage time of the remote control. Users can provide power to the module by using an XT30-USB adapter cable to connect to an external battery. The usage method is shown in the following figure.

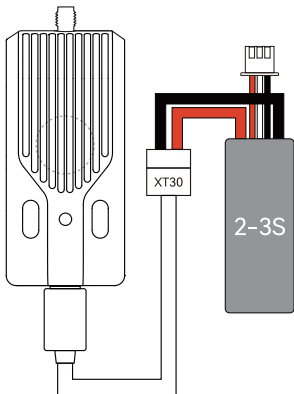

Note: When the voltage of the remote control battery or external battery is lower than 7V (2S) or 10.5V (3S), please do not use the 500mW and 1W, otherwise the module will be rebooted due to insufficient power supply, resulting in disconnection and loss of control.

## Q&A

### [Q1] Unable to enter LUA script.

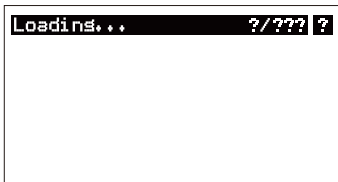

Possible reasons are as follows:

1. The TX module is not well connected to the remote control, need to check whether the Nano pin of remote control and the TX module socket are in good contact;
2. The version of ELRS LUA script is too low, and needs to be upgraded to elrsV3.lua;
3. The baudrate of the remote control is too low, set it to 400K or above (if there is no option to set the baud rate of the remote control, you need to upgrade the firmware of the remote control, e.g., the EdgeTX needs to be V2.8.0 or above).

### [Q2] Packet Rate cannot be set to F1000 or prompt "Baud rate is too low".

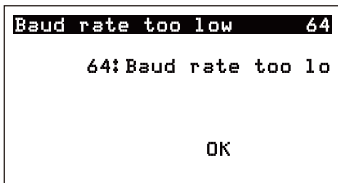

|              |             |
|--------------|-------------|
| <b>SETUP</b> | 2/12        |
| Internal RF  |             |
| Mode         | OFF         |
| External RF  |             |
| Mode         | CRSF        |
| Baudrate     | <b>400k</b> |
| Status       | 500Hz 4Err  |
| Ch. Range    | CH1-16      |

Reason: The problem is caused by the baud rate of the remote control is too low, because F1000 packet rate needs above 400K baud rate support to work.

Solution: You first need to update the baud rate (greater than 400K is fine) setting in the Model Setup menu or System menu->Hardware, and then reboot the remote control to make sure the baud rate setting has been applied.

[Q3] The packets between the remote control and the TX module is less than 1000, while F1000 packet rate is turn on.

|                        |                |          |
|------------------------|----------------|----------|
| <b>BFPV Nano TX V2</b> | <b>0/571</b>   | <b>C</b> |
| Packet Rate            | F1000(-104dbm) |          |
| Telem Ratio            | Std(1:64)      |          |
| Switch Mode            | Wide           |          |
| Model Match            | Off(ID: 0)     |          |
| > TX Power(100mw)      |                |          |
| > VTX Administrator    |                |          |
| > WiFi Connectivity    |                |          |
| > Backpack             |                |          |
| [BLE Joystick]         |                |          |
| [Bind]                 |                |          |
| 3.3.1 ISM2G4 b08b82    |                |          |
| > Other Device         |                |          |

Reason: This issue is caused by synchronization issues with the remote control system EdgeTX.

Solution: Upgrade the EdgeTX version of the remote control to 2.8.0 or above.

## More Information

As ExpressLRS project is still in frequently update, please check BETAFPV Support (Technical Support -> ExpressLRS Radio Link) for more details and newest maunal.

<https://support.betafpv.com/hc/en-us>

- Newest user manual;
- How to upgrade the firmware;
- FAQ and troubleshooting.