



SuperP 14CH分集接收机 使用说明书



Welcome to ExpressLRS!

第1版 2023-05-30

BETA FPV SuperP 14CH分集接收机，是基于开源项目ExpressLRS新一代无线遥控系统开发的产品。ELRS系统具有遥控距离长，连接稳定，低延迟，刷新率高，配置灵活等特点。

项目Github地址：<https://github.com/ExpressLRS>

SuperP 14CH分集接收机2.4G版本基本参数如下：

- 重量：15.6g
- 尺寸：46.9mm*32.7mm*14.6mm
- TLM功率（回传功率）：100mW（20dBm）
- 频段：2.4GHz ISM
- 工作电压：3.5V~8.4V
- 额定电流：180mA@5V
- 天线接口：2*IPEX MHF 1
- 天线长度：150mm
- 数据输出：PWM/CRSF/SBUS
- PWM通道数：14通道

SuperP 14CH分集接收机2.4G版本的产品框图如下所示：

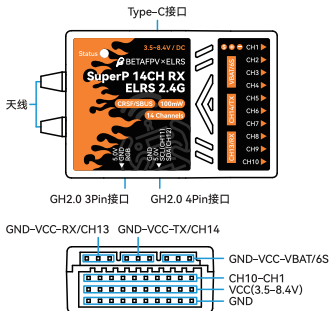

SuperP 14CH分集接收机915M/868M版本基本参数如下:

- 重量: 15.9g
- 尺寸: 46.9mm*32.7mm*14.6mm
- TLM功率 (回传功率) : 50mW (17dBm)
- 频段: 868MHz EU/915MHz FCC
- 工作电压: 3.5V~8.4V
- 额定电流: 140mA@5V
- 天线接口: 2*IPEX MHF 1
- 天线长度: 150mm
- 数据输出: PWM/CRSF/SBUS
- PWM通道数: 14通道

SuperP 14CH分集接收机915M/868M版本的产品框图如下所示:

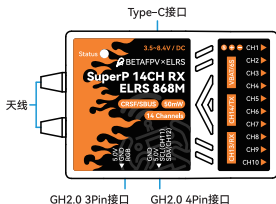
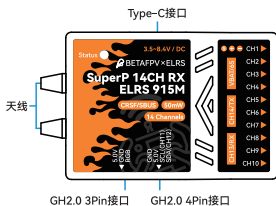

GND-VCC-RX/CH13 GND-VCC-TX/CH14

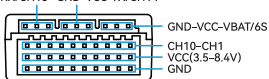

注意：VBAT 为电池电压检测端口，支持1~6S电池电压检测；
接收机配置使用CRSF输出时，CH13变为RX，CH14变为TX；
接收机配置使用SBUS输出时，CH13无输出，CH14变为SBUS；
接收机的CH11和CH12已被出厂默认配置为I2C串口，此时CH13变为CH11，CH14变为CH12；
端口功能配置网页：<http://10.0.0.1/hardware.html>

接收器状态指示灯含义：

指示灯颜色	状态	含义
彩虹	渐变	开机启动
绿色	慢闪	WiFi升级模式
红色	快闪	未检测到射频芯片
橙色	双闪	绑定模式
橙色	三闪	已连接，但与模型匹配中的设置不符
橙色	慢闪	等待连接
	常亮	已连接，颜色表示刷新率

刷新率对应的RGB灯颜色如下图所示：

2.4G:



F1000 F500 D500 D250 500Hz 333Hz 250Hz 150Hz 100Hz 50Hz

915M/868M:

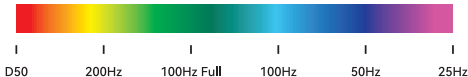

F1000和F500是FLRC模式下的刷新率，仅ELRS 2.4G支持该模式，该模式提供更快的调制和更低的延时，但接收距离比普通的Lora模式要短，适用于竞赛；

D500和D250是DVDA (Déjà Vu Diversity Aid) 模式下的刷新率，该模式工作在FLRC模式的F1000刷新率下，通过多次发送相同的数据包在有复杂干扰的情况下提供更可靠的链路连接，D500和D250分别表示将相同的数据包重复发送两次和四次；

D50是ELRS Team900的特有模式，在Lora模式的200Hz刷新率下，将相同的数据包重复发送四次，接收距离与200Hz相当；100Hz Full 是在Lora模式的200Hz刷新率下实现16通道全分辨率输出的模式，接收距离与200Hz相当。

对频

接收机出厂固件使用的是ExpressLRS V3.3.0正式版协议，而且没有设置对频密码 (Binding Phrase)。所以对频的高频头也必须是ExpressLRS V3.0.0以上版本，并且未设置对频密码。

1. 通过连续给接收机上电、断电三次，上电、断电时间保持2秒，进入对频状态；
2. 接收机上RGB进入橙色两次快速闪烁，表示处于对频模式；
3. 使用遥控器或者高频头和接收机进行对频；如果接收机RGB变为常亮，则表示对频成功。

注意：对频一次，接收机会记住对频信息，以后重启会自动连接成功，无需重新对频；

如果重刷了接收机的固件，并且配置了对频密码 (Binding Phrase)，则无法通过上面方式进入对频状态。请将高频头也设置相同的对频密码，高频头和接收机则可以自动对频连接；建议将接收机的两个天线尽可能地分开摆放，以获得更好的接收效果。

失控保护和通道输出设置

接收机在失去信号、不受控制后，失控保护功能会自动启动，此时各通道将保持预设的失控保护状态值以维持设备运行，保护设备以及人员安全。在不使用飞控进行飞行时（例如直升机或固定翼），提前设置失控保护状态值可以最大限度地保证飞行安全。

接收机的CH11~CH14不仅可以作为PWM信号的输出端口，也可以设置为通信串口。例如CH11和CH12可以设置为SCL和SDA以外接气压计等I2C串口传感器，CH13和CH14可以设置为CRSF或SBUS以连接飞控等设备。

设置方法如下：

- 接收机上电启动后，在不连接遥控器的情况下等待60秒；
- RGB指示灯进入绿色慢闪状态，接收机自动打开WiFi（WiFi名称：ExpressLRS RX，WiFi密码：expresslrs）；
- 使用手机或者电脑连接WiFi，浏览器登录<http://10.0.0.1>即可找到通道输出配置和失控保护设置页面。

输出	模式	输入	反向	750us?	失控保护值
1	50Hz ▾	CH1 ▾	<input type="checkbox"/>	<input type="checkbox"/>	1500 ▾
2	50Hz ▾	CH2 ▾	<input type="checkbox"/>	<input type="checkbox"/>	1500 ▾
⋮	⋮	⋮	⋮	⋮	⋮
13	50Hz ▾	CH13 ▾	<input type="checkbox"/>	<input type="checkbox"/>	1500 ▾
14	50Hz ▾	CH14 ▾	<input type="checkbox"/>	<input type="checkbox"/>	1500 ▾

失控保护设置

在失控保护值输入失控时舵机的输出值即可。

注意：

- 不要勾选“反向”；
- 如果勾选了“750us”标志，则失控保护值需要减半；

- 失控保护值大于1500时，模式将会自动转换为“On/Off”模式。

通道输出设置

通道输出模式一共有以下几种：

- 50-400Hz：输出PWM信号频率；
- 10KHzDuty：用于直接驱动微型电机；
- ON/OFF：输出高电平或低电平；
- Serial TX/RX：串行通信端口。

CRSF/SBUS输出设置

1. 将通道13的模式设置为Serial RX或将通道14的模式设置为Serial TX；

13	Serial RX	▼	CH13(AUX9)	▼
14	Serial TX	▼	CH14(AUX10)	▼

2. 在Serial Protocol中选择串口协议，点击“SAVE”保存设置；

Serial Protocol
Set the protocol used to communicate with the flight controller.
Serial Protocol
SBUS

3. 在options页面设置波特率（SBUS串口协议不能设置波特率）；

UART baud
420000

4. 点击“SAVE&REBOOT”即完成CRSF/SBUS输出的设置。

注意：

接收机配置使用CRSF输出时，CH13变为RX，CH14变为TX；

接收机配置使用SBUS输出时，CH13无输出，CH14变为SBUS。

I2C通信串口设置

I2C通信端口在网页：<http://10.0.0.1/hardware.html>中设置，进入方法和以上相同。

1. 将PWM输出引脚中的19和22删除；

PWM



PWM output pins

Comma-separated list of pins used for PWM output

2. 将19和22写入到I2C的SCL和SDA引脚输入框内；

I2C

SCL pin  I2C clock pin used to communicate with I2C devices

SDA pin   I2C data pin used to communicate with I2C devices

3. 点击“SAVE TARGET CONFIGURATION”即完成I2C通信串口的设置。

注意：

接收机的CH11和CH12已被出厂默认配置为I2C串口，此时CH13变为CH11，CH14变为CH12。

更多信息

由于ExpressLRS项目还处于更新活跃期，更多详细的信息，如常见问题，最新的说明书等，请到BETA FPV官方支持（技术支持->ExpressLRS遥控系列）下获取。

<https://support.betafpv.com/hc/zh-cn>

- 最新说明书；
- 如何升级固件；
- 常见问题。



SuperP 14CH Diversity Receiver

User Manual



Welcome to ExpressLRS!

BETA FPV SuperP 14CH Diversity Receiver is a new generation wireless remote system product developed based on the open-source ExpressLRS project. ExpressLRS features Long-range, stable, low latency, and high packet rate for link performance.

Link to ExpressLRS GitHub Project: <https://github.com/ExpressLRS>

SuperP 14CH Diversity Receiver 2.4G Version has the below specifications:

- Weight: 15.6g
- Dimension: 46.9mm*32.7mm*14.6mm
- TLM Power: 100mW (20dBm)
- Frequency Band: 2.4GHz ISM
- Working Voltage: 3.5V~8.4V
- Rate Current: 180mA@5V
- Antenna Port: 2*IPEX MHF 1
- Antenna Length: 150mm
- Signal Supported: PWM/CRSF/SBUS
- PWM Channel number: 14

Schematic Diagram of SuperP 14CH Diversity Receiver 2.4G is shown below:

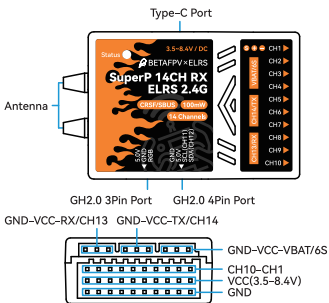

SuperP 14CH Diversity Receiver 915M/868M Version has the below specifications:

- Weight: 15.9g
- Dimension: 46.9mm*32.7mm*14.6mm
- TLM Power: 50mW (17dBm)
- Frequency Band: 868MHz EU/915MHz FCC
- Working Voltage: 3.5V~8.4V
- Rate Current: 140mA@5V
- Antenna Port: 2*IPEX MHF 1
- Antenna Length: 150mm
- Signal Supported: PWM/CRSF/SBUS
- PWM Channel number: 14

Schematic Diagram of SuperP 14CH Diversity Receiver 915M/868M is shown below:

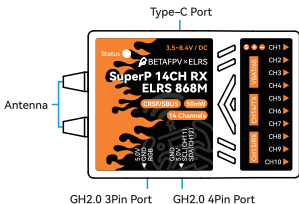
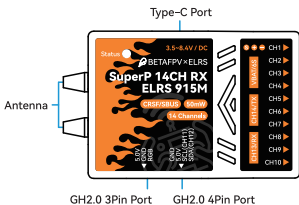

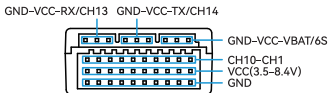

Note:

The voltage detector port for battery is set up at VBAT, which supports detecting 1~6S battery Voltage.

When configuring CRSF output, CH13 becomes RX, and CH14 becomes TX;

When configuring SBUS output, CH13 has no output, CH14 becomes SBUS;

The receiver's CH11 and CH12 are set on I2C output by default, here CH13 becomes CH11, and CH14 becomes CH12;

Channel Configuration Page: <http://10.0.0.1/hardware.html>

Receiver status RGB indications are shown as below.

RGB Color	Status	Implication
Rainbow	Fade effect	Power on
Green	Slow flash	WiFi upgrading mode
Red	Quick flash	No RF chip was detected
Orange	Double flash	Binding mode
Orange	Triple flash	Connected but mismatched model-match configuration
Orange	Slow flash	Waiting for the connection
	Solid on	Connected and color indicates packet rate

The packet rate correspond to the RGB indicator color as shown below:

2.4G:



F1000 F500 D500 D250 500Hz 333Hz 250Hz 150Hz 100Hz 50Hz

915M/868M:



I I I I I I
D50 200Hz 100Hz Full 100Hz 50Hz 25Hz

F1000 and F500 are the only packet rates supported by ELRS 2.4G under FLRC mode. Per mode features a lower latency rate and faster configuration. However, the receiving distance would be shorter than Lora standard mode. It's better suited for racing purposes.

D500 and D520 is packet rate under DVDA (Déjà Vu Diversity Aid) mode. Works under F1000 rate of FLRC mode. It repeatedly sends multiple identical packets under a complex environment, ensuring a safer radio link connection. D500 and D250 respectively send the same packet twice and four times repeatedly.

D50 is an exclusive mode under ELRS Team900. It will send packets four times repeatedly under 200Hz Lora Mode. Its receiving distance is equivalent to 200Hz.

100Hz Full is the mode that can achieve 16-channel full resolution output at the 200Hz packet rates of Lora mode. Its receiving distance is equivalent to 200Hz.

Bind

Stock firmware used for SuperP 14CH Diversity Receiver is ExpressLRS version 3.3.0. There is no Binding Phrase pre-set. Hence Binding with transmitters has to ensure that the module is using V3.0.0 above with no binding phrase being set up.

1. Power on and off the receiver 3 times, each step pausing 2 seconds to enter binding mode;
2. When the indicator starts fast blink with orange twice, the receiving is at binding mode;
3. Enter the radio or transmitter module's binding mode to bind with the receiver; if the Indicator has turned solid, it indicates that the device has been bound successfully.

Note: After the device has been successfully bound, the receiver will record the device, and future binding will be automatic. There would be no need to go through the binding process again.

If the receiver has been flashed with firmware on the configurator and is set with a binding phrase, then using the above binding method will not let the receiver be bound to other devices. Please set the same binding phrase to the transmitter module to perform an auto-bind with the receiver. It is recommended to separate the two antennas as far as possible to achieve better-receiving performance.

Failsafe and Channel Output Mode Setup

When the connection or signal is lost between the radio transmitter and receiver, failsafe function will adjust all the channels to the failsafe values you have set. All channels will maintain working with the preset value to keep the device continuously functioning to ensure device and personal safety. It's necessary to set up failsafe values properly if you are not using a flight controller, such as an RC plane or fixed-wing. The receiver's CH11-14 not only can be used as PWM signal output port, it could also be configured as Serial Port. For example, CH11 and CH12 can be configured as SCL and SDA to connect to External Barometer or other sensors that uses I2C port. CH13 and CH14 can be configured as CRSF or SBUS to connect to flight controller or other component.

Configuration for setting up is shown as below steps:

- Power on the receiver and wait for 60 seconds without binding to any transmitted equipment;
- Once the RGB indicator is in slow green flashing, the receiver's WiFi has been activated;
- Connect WiFi via cellphone or PC (WiFi name: ExpressLRS RX, password: expresslrs) ;
- Open the website address: <http://10.0.0.1>, you can find the model page for failsafe values and channel output setup.

Output	Mode	Input	Invert?	750us?	Failsafe
1	50Hz ▾	CH1 ▾	<input type="checkbox"/>	<input type="checkbox"/>	1500 ▾
2	50Hz ▾	CH2 ▾	<input type="checkbox"/>	<input type="checkbox"/>	1500 ▾
⋮	⋮	⋮	⋮	⋮	⋮
13	50Hz ▾	CH13 ▾	<input type="checkbox"/>	<input type="checkbox"/>	1500 ▾
14	50Hz ▾	CH14 ▾	<input type="checkbox"/>	<input type="checkbox"/>	1500 ▾

Failsafe Value Setup

Enter the 988~2012 failsafe value of servo into failsafe.

Note:

- Do not use "invert" flag.
- Value will be halved if "750us" flag is set.
- When failsafe value is above 1500, Mode will automatically change to "on/off" mode.

Channel Output Mode Setup

- 50-400Hz: PWM frequency;
- 10KHzDuty: Used to directly drive micro motors;
- ON/OFF: Outputting High or Low power level;
- Serial TX/RX: Serial Port.

CRSF/SBUS Output setup

1. Set CH 13 to Serial RX or set CH14 to Serial TX

13	Serial RX ▾	CH13(AUX9) ▾
14	Serial TX ▾	CH14(AUX10) ▾

2. Select SBUS in Serial Protocol and click "SAVE";

Serial Protocol

Set the protocol used to communicate with the flight controller.

Serial Protocol
SBUS

3. In options page, enter value into UART baud. (SBUS port does not support configuring UART baud value);

UART baud
420000

4. Click "SAVE&REBOOT" to finish configuring CRSF/SBUS port.

Note:

When configuring CRSF output, CH13 becomes RX, and CH14 becomes TX;
When configuring SBUS output, CH13 has no output, CH14 becomes SBUS.

I2C Port Setup

Page to configure I2C: <http://10.0.0.1/hardware.html> method to enter is as same as above mentioned.

1. Delete 19 and 22 from PWM output pins value;

PWM



PWM output pins

Comma-separated list of pins used for PWM output

2. Enter 19 and 22 into I2C's SCL Pin and SDA pin respectively;

I2C

SCL pin  I2C clock pin used to communicate with I2C devices

SDA pin   I2C data pin used to communicate with I2C devices

3. Click "SAVE TARGET CONFIGURATION" to finish configuring I2C port setup.

Note: Receiver's CH11 and CH12 has been set to I2C port by default, which CH13 becomes CH11, and CH14 becomes CH12.

More Information

As ExpressLRS project is still in frequent updates, please check BETA FPV Support (Technical Support -> ExpressLRS Radio Link) for more details, common issues and the newest manual.

<https://support.betafpv.com/hc/en-us>

- Latest user manual;
- How to upgrade the firmware;
- FAQ and troubleshooting.