



Cetus Lite

Kit

User Manual

Version No.2 2023-03-02

Contents

1. Product List	3
2. Preflight Checks	4
3. Quick Start Guide	5
3.1 Quick Start	5
3.2 Flight Operation	8
3.3 Flight Modes	10
3.4 Battery Charging	10
4. Remote Control Radio Transmitter	12
4.1 Switch Functions	13
4.2 Joystick Functions	15
4.3 Charging the Remote Control Radio Transmitter	18
5. LED Light/Beep Status Codes	17
5.1 Quadcopter LED Light	17
5.2 Remote Control Radio Transmitter LED Light & Beep Status Codes	19
6. Advanced Settings	20
6.1 Updated to Cetus Lite FPV version	20
6.2 Re-Bind for Quadcopter	21
6.3 Quadcopter Level Calibration	22
6.4 Joystick Calibration	22
6.5 Switching Protocol	23

7. FAQ	24
7.1 How to Replace Propellers and Motors	24
7.2 Radio Connecting to Simulator	25
7.3 How to Stop After A Collision	26
8. Supplement	27
8.1 Warning & Security	27
8.2 Precautions for Battery Use and Charging	27
8.3 After-Sale Service	28

1. Product List

1 x Cetus Lite FPV Brushed Whoop Quadcopter

1 x LiteRadio 1 Transmitter (CC2500 Version)

Box Contents:

2 x BT2.0 300 mAh 1S Lipo Battery

1 x BT2.0 Battery Charger and Voltage Tester

1 x USB Charging Cable (Type-C)

1 x Type-C Adapter (adapter board+4PIN connector cable)

1 x Prop Removal Tool

4 x 31mm 4-Blade Prop (Replacement)

1 * 716 CW motor

1 * 716 CCW motor

2. Preflight Checks

1. Check all parts are included according to product check-list. Ensure all parts are intact and the frame undamaged.
2. Verify that propellers and motors are installed correctly and stably.
3. Ensure that propellers do not scratch against frame ducts and motors spin smoothly.
4. Verify batteries (of quadcopter and remote control radio transmitter) are fully charged.
5. Be sure pilot is familiar with all flight controls. (Refer “Remote Control Radio Transmitter”).
6. Always keep a safe distance in all directions around the quadcopter (1 meter or more) when having a test-flight. Operate the quadcopter carefully in open space.

3. Quick Start Guide

3.1 Quick Start

Before flying, verify that the remote control radio transmitter is successfully Binded with the quadcopter, all basic controls are functional, and the quadcopter can be taken off normally.

- Step 1: Take out the remote control radio transmitter, set the throttle joystick to the lowest position. Turn the power button on the bottom to the right. When it beeps three times and power indicator turns from flash red to solid blue, and release the left joystick for it to be recentered. This process indicates that radio has been turned on successfully.

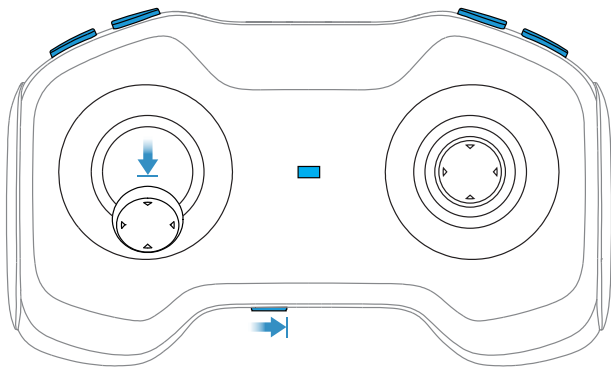

Set the Left Joystick to the Lowest Position.
And Push the Power Button to the Right.

- Step 2: Install the battery into the battery mounting slot under the quadcopter. Ensure that the direction of the battery and quadcopter's power cord is aligned in the same direction. Connect the quadcopter with the battery, then place the quadcopter on a horizontal surface. Wait 3-5 seconds until its status LED lights changes from flashing blue to solid blue. This indicates that the initialization of the quadcopter is complete and the quadcopter has binded successfully with the remote control radio transmitter.

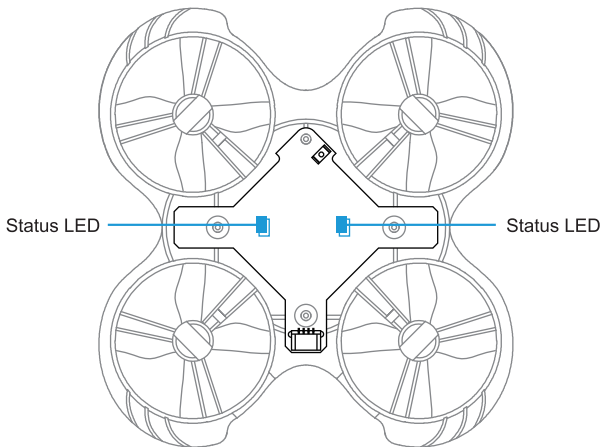

- Step 3: Press switch SA to arm the quadcopter. Then motors will start spinning slowly. Press Switch SA again to disarm the quadcopter and motors will stop spinning.

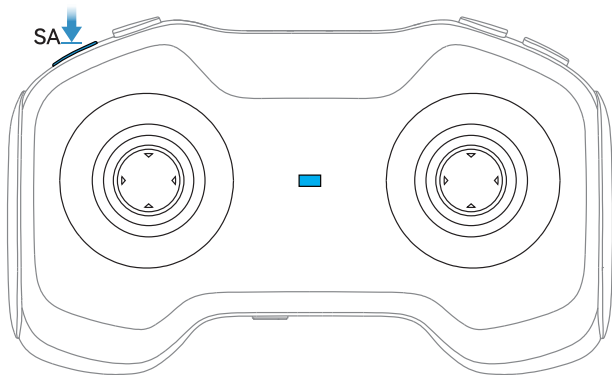

Press Switch SA to Arm the Quadcopter

The completion of these steps verifies the normal functioning of the quadcopter and remote control radio transmitter, and the following flight operations can be continued.

3.2 Flight Operation

Step 4: Re-arm quadcopter (step 3). Motors will spin at a low speed.

Throttle (left) Joystick:

- Up/down controls rate of ascent/ descent.
- Left/Right controls counterclockwise/ clockwise rotation.

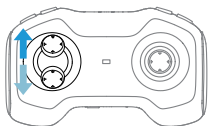

Joystick Up/Down

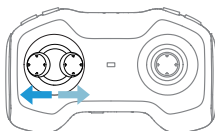
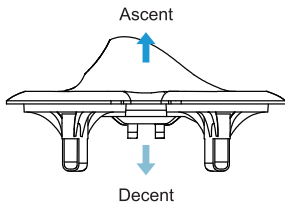

Joystick Left/Right

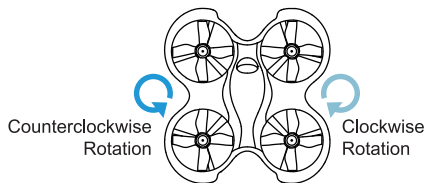

Direction (right) Joystick:

- Up/down controls forward/ backward.
- Left/right controls left/ right.

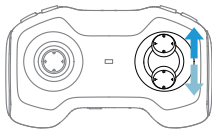

Jotstick Up/Down

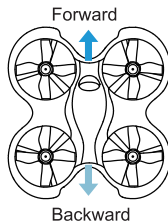

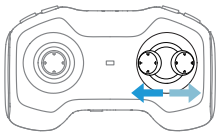

Joystick Left/Right

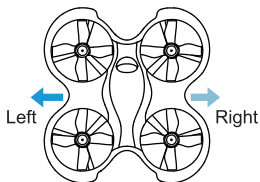

It is recommended to begin flying without using fpv goggles for practice. Be familiar with the controls and sensitivity of the joysticks by following the above-mentioned operation steps.

Caution:

1. Find a suitable open place for the first flight.
2. Push the joysticks slowly, especially the throttle joystick.
3. If the quadcopter becomes out of control or collides with objects, quickly pop-up switch SA to disarm, and motors will stop spinning.

- Step 5: Land quadcopter steadily and press switch SA to disarm, as shown below:

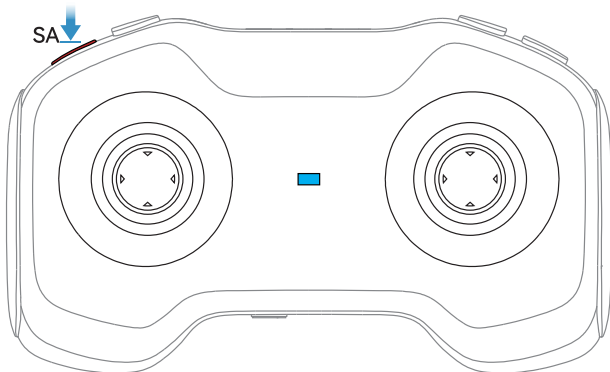

Press Switch SA to Disarm the Quadcopter

- Disconnect the battery with the quadcopter by removing it from the mounting slot. Push the power button on the bottom to the left, the LED indicator turns off. This indicates that the remote control radio transmitter has been powered off.

3.3 Flight Modes

Cetus Lite FPV only supports Normal Mode (N MODE). And there is no Sport Mode (S MODE) or Manual Mode (M MODE).

N MODE: When the quadcopter ascends, center two joysticks at the same time. Then quadcopter will maintain a horizontal attitude at a certain height. The position of the directional joystick controls the tilt direction and tilt angle of quadcopter. It also has an auxiliary flight function, which can assist in adjusting the altitude position, but can not adjust the horizontal position.

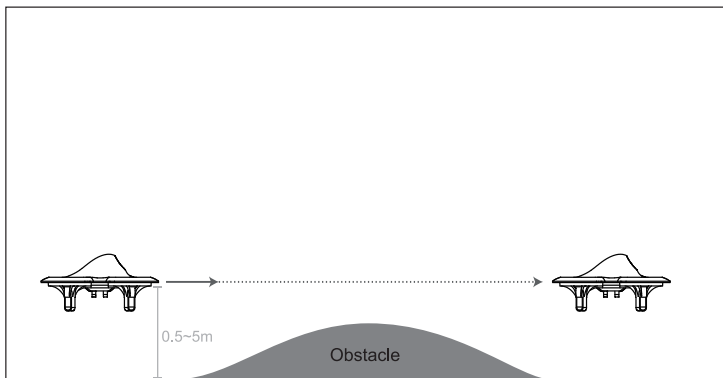

Caution 1: When flying in Normal mode, please try to choose an indoor or windless outdoor environment., keeping the flight height within 0.5m-5m. Meanwhile, the outdoor flight height should not exceed 5m. When in a harsh environment, such as flying in a strong wind, the quadcopter may not be controlled, drift and fall.

Caution 2: If you want to experience the auxiliary flight function in both altitude and horizontal positions, when in normal mode (N MODE), sport mode (S MODE), and manual mode (M MODE), please try Cetus or Cetus Pro kit, which supports more flight modes.

3.4 Battery Charging

Each battery provides 4-5 minutes of smooth flight. When LED indicator on the quadcopter started flashing red, indicating the battery is low on power and needs to be recharged. Charging steps are as follows:

- Connect the charger with a Type-C port USB cable;
- Connect one or two batteries to the port on the right of the charger and the charger's LED indicator will turn solid red while charging;
- When the charger's LED indicator turns solid green, charging process is complete.

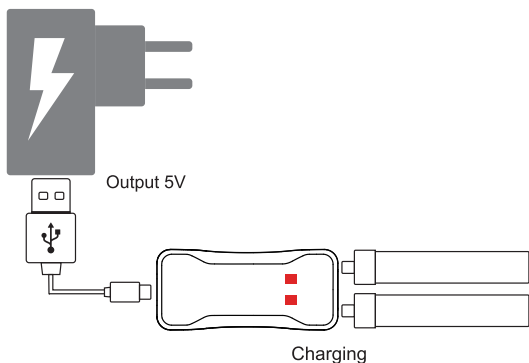

Two batteries can be charged at the same time. Charging a fully discharged battery takes approximately 20 minutes. When the charger is not connected to a USB cable and connector, inserting the battery to the TEST port of the charger can display the current battery level. The number of 4.25-4.35 represents a fully charged battery while 3.30 or lower indicates a low battery.

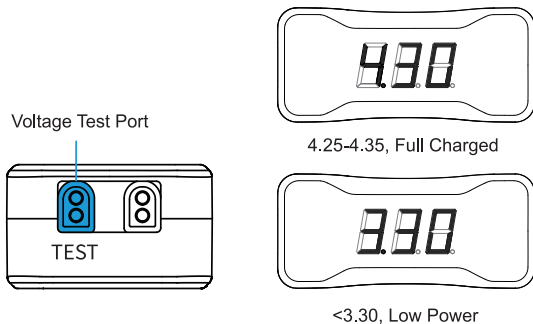

4. Remote Control Radio Transmitter

The remote control radio transmitter in this kit is LiteRadio 1 model.

Switch instructions as shown below.

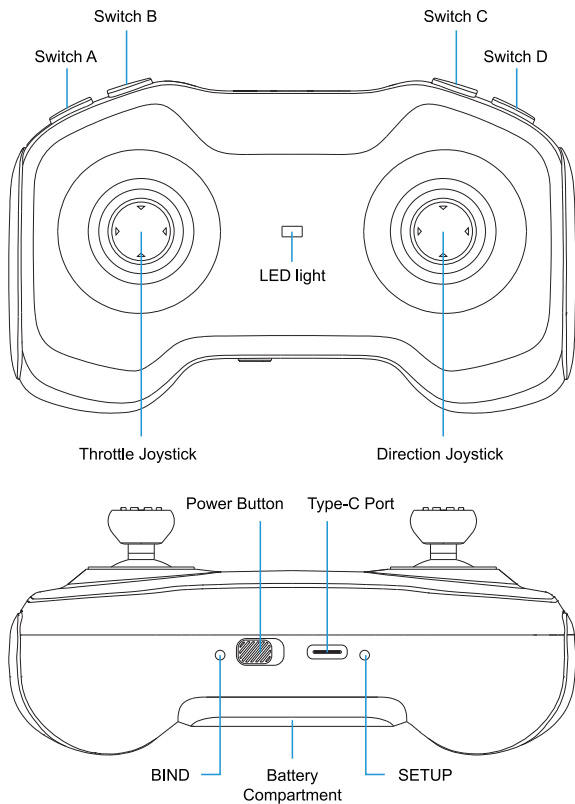

The LiteRadio 1 is compatible with two types of joystick heads. When replacing the joystick head, please be aware NOT to twist the joystick head. Instead, pull it out directly, then replace the joystick head. As shown below:

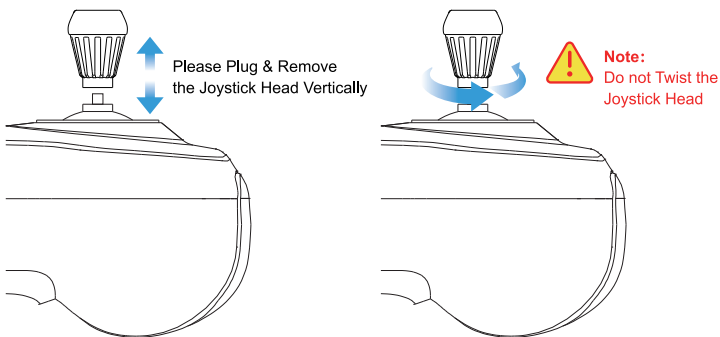

4.1 Switch Functions

Four switches are provided on the front of the remote control radio transmitter: SA, SB, SC, and SD, as shown below. Pilots can change different statuses and parameters of the quadcopter. Please take notice that these switches can only work after the remote control radio transmitter is successfully binded to the quadcopter.

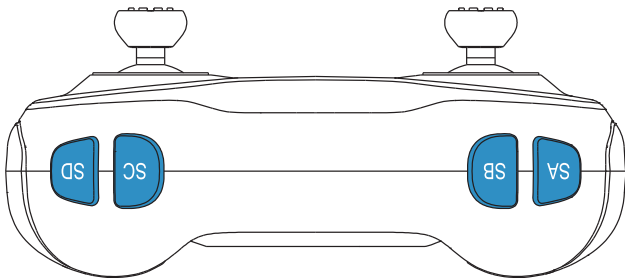

Switch SA: Arm/Disarm Quadcopter

- Press switch SA to disarm
- Re-press switch SA to arm

Switch SB: Quadcopter Level Calibration

- Press Switch SB to perform Level Calibration

Switch SC: Speed Threshold of Quadcopter

- Pop-up switch SC and change to slow mode(SLOW)
- Pop-down switch SC and change to fast mode(FAST)

When quadcopter is flying in a low gear(SLOW), quadcopter body is slightly tilted front with angle 3-5 degrees, and movement speed is around 2m/s;

When quadcopter is flying in a high gear(FAST), quadcopter body is slightly tilted front with angle 5-10 degrees, and movement speed is around 3.5m/s.

Switch SD: Button left unused without function.

Switch SD is meant for switch Video Transmitter(VTX) frequency when per kit is upgraded to FPV version.

There are also 3 buttons at the bottom of the remote control radio transmitter.

Functions are as follows:

- Power Button: Push to the right to turn on, and Push to the left to turn off;
- BIND Button: Enter binding mode with a short press (active after the remote control radio transmitter is powered on);
- SETUP Button: Enter joystick calibration mode with a short press (active after the remote control radio transmitter is powered on);

Refer “Advanced Settings” for more information on binding or joystick calibration.

4.2 Joystick Functions

Two joysticks (throttle&direction joysticks) on the front of the remote control radio transmitter control the quadcopter: Ascent/descent (throttle), forward/backward tilt (pitch), left/right tilt (roll), and rotation of flight direction(yaw).

Throttle (left) Joystick - Ascent/descent (throttle) and rotation of flight direction (yaw).

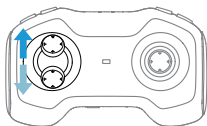

Joystick Up/Down

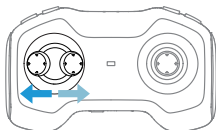
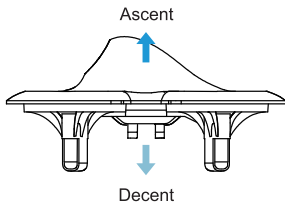

Joystick Left/Right

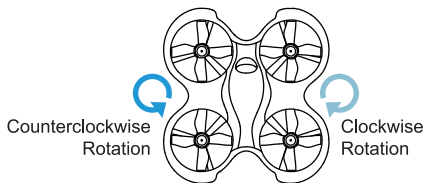

Direction (right) Joystick - forward/backward tilt (pitch) and left/right tilt (roll).

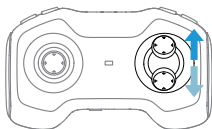

Jotstick Up/Down

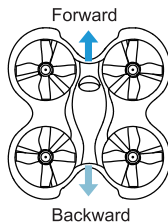

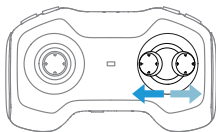

Joystick Left/Right

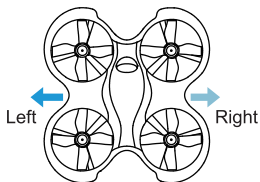

4.3 Charging the Remote Control Radio Transmitter

Remote control radio transmitter has a built-in 1000mAh battery. When red light flashes twice and the buzzer alarms twice, indicates that radio transmitter is low battery and needs to be recharged. Below are the charging methods for reference:

- Turn off the radio transmitter;
- Plug in remote control radio transmitter with adapter by USB cable (5V output adapter is allowed);
- The LED light breathes in red means charging, while in green means fully charged.

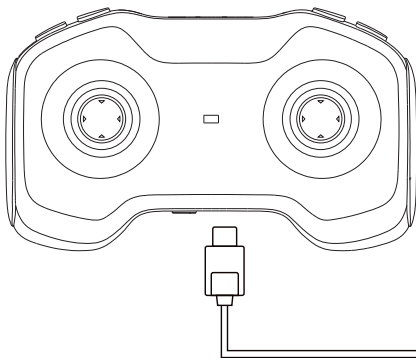

Type-C Data Cable

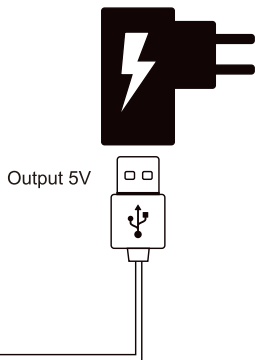

The continue working time for full charged battery is about 8 hours.

When battery is fully charged and left being unused within 30 days, battery power can still maintain about 80%.

Fast charging protocol is not supported. So radio transmitter can not be quickly charged.

5. LED Light/Beep Status Codes

5.1 Quadcopter LED Light

There are two RGB LED indicator on the bottom of the quadcopter.

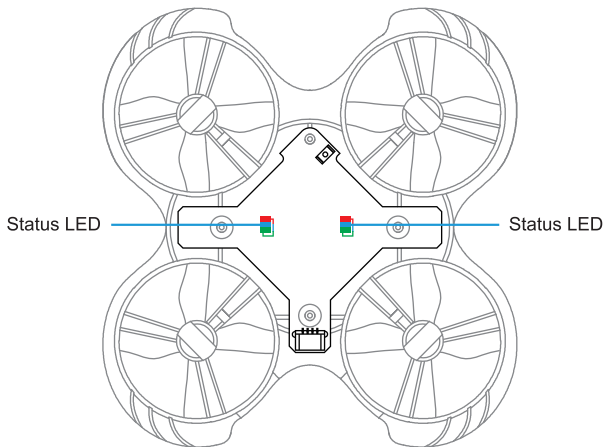

Status LED color	Status	State description	Solution
—	Off	The power on the quadcopter is abnormal or off	Replace the battery and power on again
Red	Flashing slowly	Quadcopter battery is low	Replace the battery
Blue	Solid	The quadcopter is connected with the remote control radio transmitter	
Blue	Flashing fast	Quadcopter is horizontal calibrating	Place the quadcopter on a horizontal surface and wait for a while
Purple	Solid	Quadcopter accessed the OSD menu	Unplug the battery and power it on again
Green	Flashing fast	Quadcopter is in binding mode	
White	Flashing fast	Arming failed, because the throttle joystick was not in the center position when arming	Disarm, and place the throttle joystick at the center position
Amber	Flashing slowly	Loss of remote control radio transmitter signal	Re-establish the connection with the remote control radio transmitter

5.2 Remote Control Radio Transmitter LED Light & Beep Status Codes

There are two RGB LED indicator on the bottom of the quadcopter.

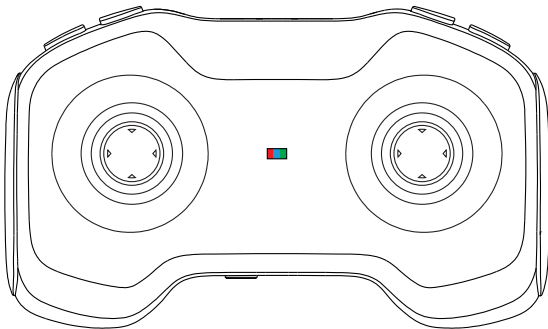

Indicator LED color	Status	State description	Solution
Red	Solid	Throttle joystick is not at the lowest position when starting	Move throttle joystick to the lowest position
Red	Flashing fast	Remote control radio transmitter is in binding mode	Wait for binding
Red	Flashing slowly	Battery voltage is too low	Charge remote control radio transmitter

There is a built-in beeper, pilot can recognize the working status of the remote control radio transmitter by its sound.

Beep	State description
The buzzer alarms twice: di-di	Low battery

6. Advanced Settings

6.1 Updated to Cetus Lite FPV version

Cetus Lite Kit can be updated to Cetus Lite FPV Kit. The Cetus Lite Kit is suitable for beginners to practice basic flight operations. User can fly with FPV goggles to experience immersive flying from First Person View.

Here are the differences between Cetus Lite Kit and Cetus Lite FPV Kit:

Cetus Lite Kit	Cetus Lite FPV Kit
Cetus Lite Brushed Whoop Quadcopter	Cetus Lite FPV Brushed Whoop Quadcopter
LiteRadio 1 Transmitter (CC2500 Version)	LiteRadio 1 Transmitter (CC2500 Version)
Without	BEATFPV VR02 FPV Goggles
Without	Cetus Camera +VTX Module (assembled in the quadcopter)

Cetus Lite FPV Kit comes with one additional VR02 FPV goggles comparing the Cetus Lite Kit. Cetus Lite FPV Kit's quadcopter is has equipped one additional with Cetus Camera + VTX Module than Cetus Lite Kit. When user need to update to Cetus Lite FPV Kit, user only needs to buy a VR02 FPV goggles and a Cetus Camera + VTX Module. After assembling the additional parts, user can enjoy the immersive experience of FPV flying.

Cetus Camera+VTX Module and flight controller wiring diagram :

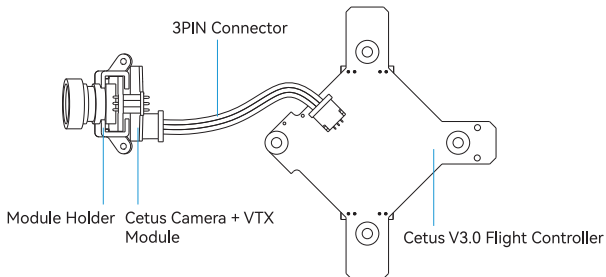

6.2 Re-Bind for Quadcopter

If quadcopter and remote control radio transmitter cannot be bound successfully, the pilot may need to re-bind. This can happen when replacing new electronic parts of the quadcopter during maintenance or upgrading the remote control radio transmitter. The steps are as follows:

- Power on the quadcopter and wait for its system to load completely;
- Use a screwdriver to lightly press the button on the quadcopter and the status light on the quadcopter turns green and starts to flash;
- Power on the remote control radio transmitter and wait for its system to load completely;
- Lightly press the BIND button on the bottom of the remote control radio transmitter with a screwdriver. The power indicator will flash red;
- If re-bind is successful, quadcopter status light will change to blue.

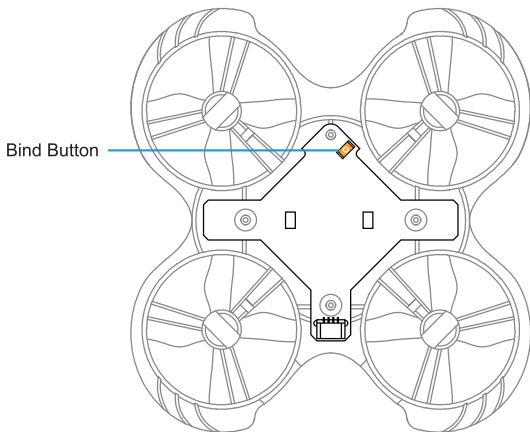

Note: The re-binding of the remote control radio transmitter and the quadcopter may not be successful after pressing the BIND button of the remote control radio transmitter once. In this situation, pilot needs to press the BIND button a second time to complete the binding.

6.3 Quadcopter Level Calibration

After the quadcopter has taken off and landed several times, the quadcopter gyroscope may become offset. This will cause the quadcopter to always tilt in the same direction during a flight. To fix up it, the quadcopter gyroscope can be recalibrated. The steps are as follows:

- Turn on the quadcopter and the remote control radio transmitter, and ensure that the connection is successful;
- Place the quad on a horizontal plane and pop-down switch SB to perform Level Calibration;
- Wait 3-5 seconds, LED indicator change from flashing blue to solid blue ;
- The initialization process is completed, the quad has finished gyroscope data calibration, and the remote control is successfully reconnected with the quad.

6.4 Joystick Calibration

The joystick data may offset after it has used for a period of time (if joystick has been hit against physically). User need to re-calibrate joysticks based on following steps:

- After powering on, press SETUP button on the back of remote control radio transmitter, it hears two "Bee Bee" sounds, and red LED flash quickly (two flashes each time), which means remote control radio transmitter entered calibration mode;
- Move throttle joystick and direction joystick to middle position, press SETUP button again, wait until the buzzer beep three "Bee Bee Bee" sounds, red LED light flashes quickly (two flashes each time), which indicates joystick data has been acquired and enter into the boundary value calibration mode;
- Toggle the joystick to move to the top, bottom, left, and right joystick boundaries respectively (do not to press too hard, the joystick just needs to touch the boundary) and keep the position for 1-2S, then press the SETUP button one more time, user can hear a long beeping sound (about 3 seconds) from the buzzer again, and the red LED light stops flashing, indicating that the calibration of the joystick is completed.

6.5 Switching Protocol

How to check the current protocol

The radio transmitter could support 4 different protocols, including Frsky D16 FCC, Frsky D16 LBT, Frsky D8 and Futaba S-FHSS.

The current protocol is indicated by the flashing times of the red LED when power on, before the buzzer alarm.

How to change the current protocol

Below are the steps to change protocol (Frsky FCC D16, Frsky D16 LBT, Frsky D8, or Futaba S-FHSS).

- Power off the radio transmitter;
- Press and hold the BIND button while power on the radio transmitter;
- Then the flash times of the red LED before buzzer alarms will change, according to the tables above.

LED Status	Protocol Version
Flash once	Frsky D16 FCC (ACCST 1.X Version)
Flash twice	Frsky D16 LBT (ACCST 1.X Version)
Flash Three Times	Frsky D8
Flash Four Times	Futaba S-FHSS

Note: LiteRadio 1 only work with D16 ACCST 1.x Frsky protocol. So if you use a Frsky receiver with D16 ACCST 2.X version or ACCESS version, binding will fail.

7. FAQ

7.1 How to Replace Propellers and Motors

Propellers can be deformed or fall off when quadcopter collides with an object. Bent or missing propellers need to be replaced.

Firstly, use the included propeller removal tool to remove propellers from the motor. The tool should be placed between the motor and the propellers. Please hold the motor instead of the frame duct with your hand when removing propellers to protect the frame from being deformed by overexertion.

Secondly, the distance between the replaced propeller and the motor is kept at about 2mm. There is no need to press down forcefully. Pressing down forcefully will cause damage to the motor or the blade to deform, and rubbing against the frame when quadcopter is powered on.

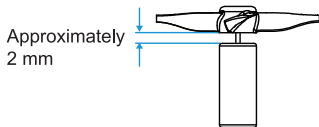

4 spare propellers are included: two each clockwise (CW) and counterclockwise (CCW). CW propeller warps clockwise. It is used on the front left or rear right motor. CCW propeller warps counterclockwise. It is used on the front right or rear left motor. Install as in the diagram below.

The CW propeller corresponds to the motor with red and blue wires, and the CCW propeller corresponds to the motor with black and white wires.

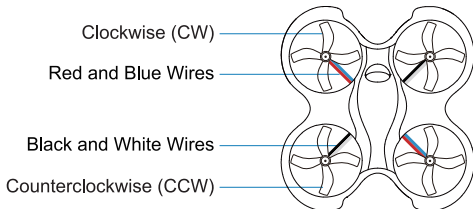

Caution: Please do not power on the quadcopter when the propeller is deformed, loosen or damaged. Quadcopter may lose control in flight per situation. User needs to replace the propeller before performing the next flight.

7.2 Radio Connecting to Simulator

It is the safest and quickest method to get started using FPV simulator for practicing FPV flights. LiteRadio 1 remote control radio transmitter supports most of the FPV simulators on market with comprehensive configuration.

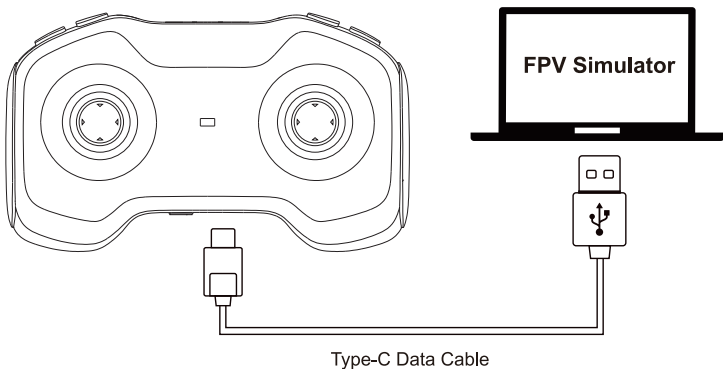

Operation steps below:

- Turn off radio transmitter;
- Connect the transmitter to computer via USB data cable. Wait for the LED light breathes in red or green;
- Install driver from PC automatically, prompt box pops up after successful installation. Then, remote control radio transmitter works normally.



Other devices



BETAFPV Joystick

User needs to manually install driver if PC doesn't install automatically or installed incorrectly.

DO NOT power on the transmitter first and connect it to the PC. The USB port is invalid in this situation.

7.3 How to Stop After A Collision

- Press switch SA on the remote control radio transmitter immediately once the quadcopter collides with an object. Press switch SA to arm the quadcopter and all motors will immediately stop spinning.
- If the flying altitude is too high and it is difficult to control, please press switch SA immediately to stop the motor.

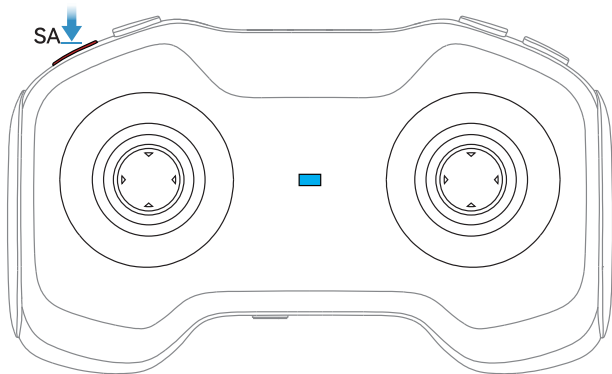

Press Switch SA to Disarm the Quadcopter

Caution: Press switch SA immediately when the quadcopter is hit or the propellers scratch against the frame duct.

8. Supplement

8.1 Warning & Security

- Move the throttle joystick as gently as possible to avoid the quadcopter ascending and descending too suddenly.
- Press switch SA on the remote control radio transmitter to stop the motor running immediately if the quadcopter collides with any object.
- Please try to keep motors perpendicular to the body. Otherwise, flight performance will be degraded.
- Learn to control the quadcopter proficiently before flying in a large outdoor area or with the wind.
- Battery life can be significantly reduced if pilot continues to fly after the low voltage warning is shown.
- Do not fly in rain. Humidity may cause unstable flight or loss of control.
- Keep the battery away from water. If the flight controller touches water, a short circuit may occur and the flight controller may burn out.
- Do not fly in inclement weather with thunderstorms or lightning.
- Do not fly in areas that are not permitted by local law.

8.2 Precautions for Battery Use and Charging

- Do not immerse the battery in water. Store in a dry area if not used for a long time.
- Keep away from children. If swallowed, seek medical attention immediately.
- Do not use or store the battery near heat sources, microwave ovens, or open flames.
- Only use a battery charger that meets the specifications when charging.
- Do not throw the battery into fire or heat the battery.
- Do not use or store the battery in an extremely hot environment, such as in a car under direct sunlight or hot weather. Overheating affects the performance of the battery and shortens the service life of the battery. Overheated batteries can catch fire.
- If the battery has a peculiar smell, temperature, deformation, discoloration, or any other abnormal phenomenon, stop using the battery. Recycle and replace the battery.
- If the battery connector gets dirty, please wipe it with a dry cloth before use. Avoid getting battery contacts dirty, which can cause energy loss or failure to charge.
- Disposing of the battery randomly may cause a fire. Please fully discharge the battery and use insulating tape to dispose of the battery output connector before disposing of

the battery. Refer to local regulations before disposing or recycling a battery.

8.3 After-Sale Service

- **Warranty:** All defective merchandise, unless otherwise indicated, may be returned for a replacement within 30 days from the date of goods received. We cannot provide refunds or replacements beyond 30 days.
- If the product is confirmed to have a quality problem (product design or quality issues), we will cover it with replacing or refund.
- All warranty replacements are required to have photos or videos and a detailed description. The warranty does not cover physically damaged merchandise. We are willing to figure out the best solutions, as always.
- For after-sale service, please reach out via e-mail: support@betafpv.com

This clause only applies to the products manufactured by BETAFPV and sold by BETAFPV authorized dealers.

The specific interpretation rights of this clause belong to BETAFPV.



<https://betafpv.com>